

SCHAEFFLER



**Rolling Bearings and Services
for Mining and Processing**





The right solution for every bearing position

One of the largest rolling bearing manufacturers worldwide, Schaeffler is a partner to all leading manufacturers and companies involved in the mining and processing industry. Our bearing solutions and service increase the functional reliability and performance of machines and processes. We help our customers reduce their overall costs with our expert technical support and a global distribution network.

Everything from a single source 4 – 5

Schaeffler product range:
The right bearings and services for any application

Mining 6 – 9

Tunnel boring machines, wheel bucket excavators
and shaft drilling machines: Bearings and services

Loading 10 – 11

Energy-saving solutions for draglines-
and rope excavators & troubleshooting package

Transport 12 – 15

Products for dump trucks and belt conveyor systems +
Money-saving advice: Split spherical roller bearings

Crushing 16 – 19

Bearing innovations for crushers, vertical mills,
roller presses, ball mills & Special Service

Sizing 20 – 21

Vibrating screen bearings with special coating
for longer service life

Finishing 22 – 23

Rotary kilns as an application for complete
bearing units, bearings for pellet plants & Arcanol

Electric motors & pumps 24

Low-friction and noise-reduced ball bearings
with energy saving potential & innovative seals

Sales & service 25

Distributor programs ensures fast help &
Special Service: Lubricating grease analysis

Worldwide network 26

Schaeffler GTN: Global expertise – local
knowledge – optimal customer performance



Schaeffler: Partner to the mining and processing industry

In mining and processing, rolling bearings are essential contributors to technological progress. Rough operating and environmental conditions require extremely robust bearings. More than one hundred years of experience in the rolling bearing business and a strong customer focus make Schaeffler an excellent choice as a partner.

Customers from sixty industrial sectors rely on the high quality of FAG and INA products. Our product range of over 225,00 industrial products is one of the largest in the rolling bearing industry.

Systems for condition monitoring, mounting services as well as maintenance tools complete our range. All of this ensures that we can offer a solution for virtually any application in the mining and processing industry.

Intensive research and development as well as constant close work with manufacturers and operators all result in high levels of operational reliability for all of our bearings. In addition, our solutions always offer economic benefits – and this increases their efficiency.

Products and services for your success



INA and FAG cylindrical roller bearing



FAG split cylindrical roller bearing



INA cylindrical roller thrust bearing



FAG spherical roller bearing



FAG split spherical roller bearing



FAG spherical roller thrust bearing



FAG tapered roller bearing



INA slewing ring



FAG four-point contact ball bearing

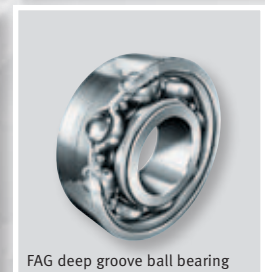

FAG deep groove ball bearing



ELGES spherical plain bearing



Machined FAG housing

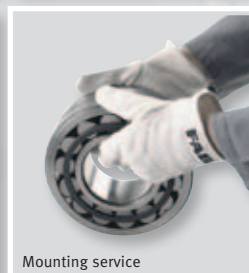

Mounting service



Lubrication



Condition monitoring

















We are thoroughly familiar with our customers' specific requirements as a result of our close cooperation with our customers and with higher education and research institutions for mining and processing. Our state-of-the-art technology permits us to supply the entire industry with the right bearings and offer related services, focusing on high reliability in even the toughest ambient conditions.

Here are just some of the benefits for our customers:

- Proven and tested quality of FAG and INA product brands
- High operational reliability
- Long life

- High load carrying capacity and stability
- Reduced maintenance costs
- Easy to install and remove
- Suitable for high vibratory stresses
- Resistant to very high temperatures

Our product range for your machines and facilities (excerpt)

Process	Facility/machine	Cylindrical roller bearings	Split cylindrical roller bearings	Spherical roller bearings	Split spherical roller bearings	Spherical roller thrust bearings	Tapered roller bearings	Cylindrical roller thrust bearings	Slewing rings	Four-point contact ball bearings	Deep groove ball bearings	Spherical plain bearings	Machined housings	Mounting	Lubrication	Condition monitoring	Reconditioning
																	
Mining	Continuous Miner	●		●			●							●	●	●	○
	Shearer loaders	●		●			●		●					●	●	●	○
	Tunnel boring machines						●		●					●	●	○	●
	Drill rigs	●		●		●	●							●	●	○	○
	Wheel bucket excavators	●	●	●	●				●	●		●	●	●	●	●	●
Loading	Draglines excavators	●		●			●							●	●	●	●
	Rope and hydraulic excavators						●							●	●	●	○
	Pickers, stackers	●	●	●	●				●	●		●	●	●	●	●	●
Transport	Dump trucks	●		●			●				●			●	●	○	○
	Conveyor systems			●	●		●						●	●	●	●	●
	Hoisting plants	●		●	●								●	●	●	●	●
Crushing	Crushers	●		●			●	●				●	●	●	●	●	●
	Vertical mills	●		●			●			●	●	●		●	●	●	●
	Roller presses	●		●		●		○				●		●	●	●	●
	Ball mills			●	○								●	●	●	●	●
Sizing	Vibrating screens	●		●										●	●	●	
Finishing	Rotary kilns			●			●					●	●	●	●	●	○
	Pellet plants, sintering facilities	●		●			●		●		●	●	●	●	●	●	

● available ○ optional

Indispensable: Bucket wheel excavators in open pit mining



stantly move up and down. That is why the bearings in the boom must be able to support static loads as well as vibrations that are due to the digging motion of the bucket wheel. Spherical roller bearings and spherical plain bearings are the best choice for these requirements.

For the bucket wheel shaft, the bearings must absorb high loads and shock loads as well as compensate shaft deflections and misalignments. Large FAG spherical roller bearings have adjustable angles and a high load carrying capacity, offering the best characteristics possible for this application.

Open pit mining of raw materials: Low speeds in combination with high loads and the frequent starting of machinery all result in stress for each component. A rating life of 75,000 hours or an operating time of ten years is required for the bearings used in this application.

The challenge

The excavator platform swivels during operation, but the boom does not con-

The solution: Split cylindrical roller bearings

In many bucket wheel excavators, the transmission for the bucket wheel drive is furnished with bearings on the bucket wheel shaft. Due to the welded-on flanges, mounting can be carried out with split cylindrical roller bearings only. This design allows the bearings to be replaced quickly, reducing downtimes as well as maintenance costs.



Angle adjustable large spherical roller bearing



Cylindrical roller bearing with triple split inner ring

High reliability guaranteed: Maintenance-free ELGES spherical plain bearings

Our ELGES brand has provided plain bearing solutions for the mining industry for over 60 years. An example of this is the ELGES spherical plain bearing with our ELGOGLIDE® high-performance sliding layer for dynamic contact pressures of up to 300 MPa. These zero-maintenance dry plain bearings offer very high load carrying capacity in very small mounting spaces. Their high-performance ELGOGLIDE® sliding layer makes them extremely durable and especially suitable for small swivelling motions.

ELGES bearings are available for radial, axial and combined loads.

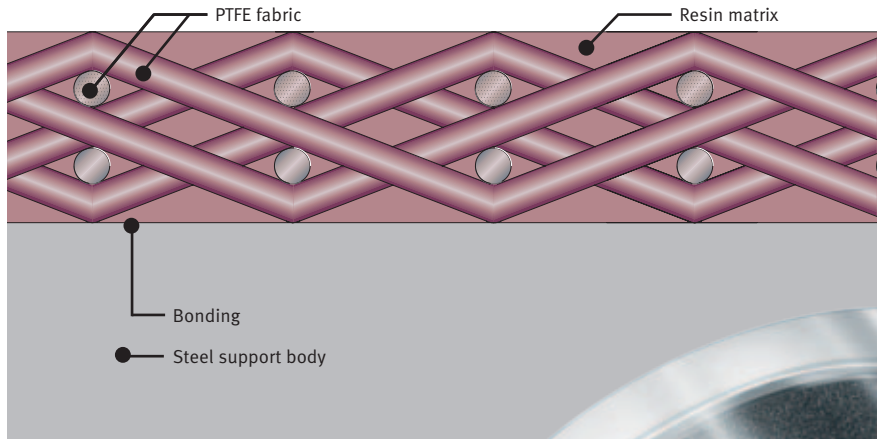

Constituents of an ELGOGLIDE® sliding layer

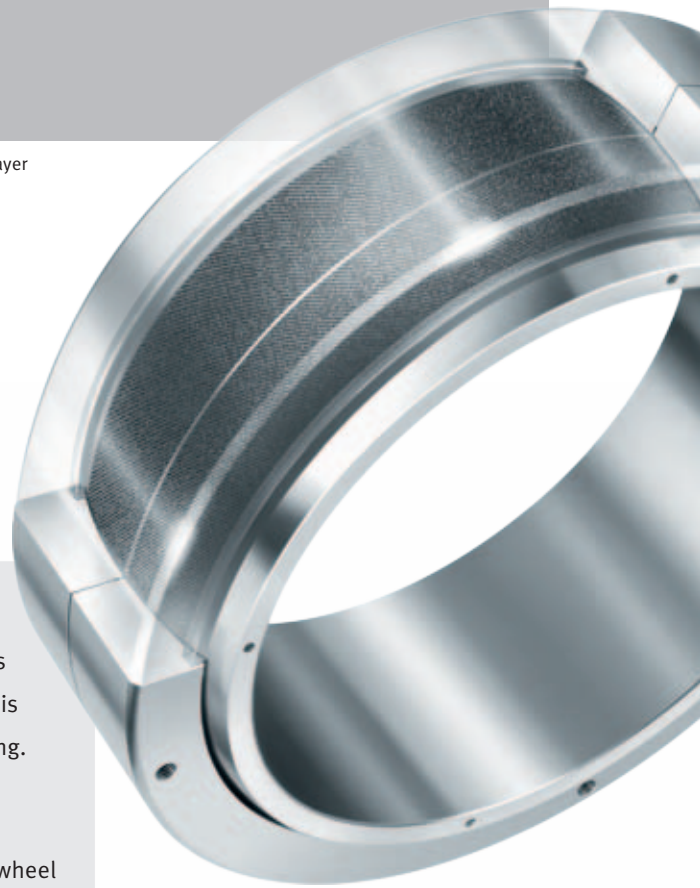

Special Service

Our experienced technicians can help you install and remove rolling bearings and provide advice on selecting the right mounting tools. Proper mounting is an essential prerequisite for achieving a maximum rating life of the bearing.

A real-life example

A surface mining company wanted to replace the bearings on the bucket wheel shaft of an excavator without having to remove the transmission in the field to save time and costs. Schaeffler worked closely with this customer to develop a tailor-made bearing for these requirements as well as special mounting tools. All of the required mounting and removal steps were prepared and carried out with the customer. This allowed the bearing to be replaced during a short, planned downtime, considerably reducing time and costs.



Giants underground: Tunnel boring machines



Calculation of a cutter bearing in Schaeffler's BEARINX® calculation program



FAG tapered roller bearing

Tunnel boring machines are used for road construction, heading and for installing supply lines. The dimensions of these machines can be enormous. Low-friction and reliable rolling bearing systems are required for cutter heads with diameters up to 20 meters.

The challenge

Hard rock, loose rock or wet soil place high demands on bearings used in various heading machines. Changing operating conditions during the heading process entail different loads, which must be

taken into consideration when designing the rolling bearings. Bearing and seal requirements include high resistance to contamination, vibrations and pressure differences.

The solution: FAG rolling bearing systems

For many decades now, Schaeffler has been a renowned and innovative premium supplier to manufacturers of tunnel boring machines. One of our products is the main bearing, which is at the heart of the tunnel boring machine. Our large axial-radial cylindrical roller bearings or tapered roller bearings in O-arrangement by FAG are ideally suited for this application. With outside diameters of several meters and weighing up to 30 tons, they can reach gigantic dimensions. The tasks of the main bearing include supporting the rotating cutter head of the machine, absorbing the enormous advancing forces and supporting the huge tilting moments.

Roller bits are another real challenge for bearing technology – characterized by high shock loads, large differences in speeds and accelerations as well as high operating temperatures. Reliable seals are indispensable for long bearing life. FAG tapered roller bearings made from case hardening steel (W209C) in O-arrangement offer everything required in this challenging application.

A huge load test for bearings: Shaft drilling



Vertical shaft drilling machines are primarily used for production and ventilation shafts and the extraction of ore, but also for installing rescue shafts. When the huge drills start running, it is important for every single machine component to be able to withstand the harsh conditions of underground mining.

Spherical thrust roller bearings with machined brass cages are used as the main bearings in drills and among other things support the weight of the drill rods and drilling forces. High-quality Schaeffler rolling bearings provide support for the various loading conditions during the drilling of the pilot hole (pre-drilling) and the subsequent extension drilling. This ensures that the entire process runs smoothly.

Special Service

Reconditioning rolling bearings and bearing units often saves costs. This service is one of Schaeffler's core competencies and is offered worldwide at several certified locations. Our services are provided for rolling bearings of any design and from all manufacturers.

Schaeffler can recondition and modify rolling bearings with outside diameters of up to 4,250 mm. Even larger bearings can be reconditioned on request, including main bearings for tunnel drilling machines.

In most cases, reconditioning costs are much lower than the cost of a new bearing – in addition to delivery times that also tend to be shorter.



Energy-intensive: Draglines and rope excavators



Large spherical roller bearings with brass cage

As draglines and rope excavator consume extremely large amounts of electricity, they are directly connected to the power grid.

The challenge

Every new start involves high costs. That is why it is essential that unplanned downtimes be avoided. The reliability of the rolling bearings used is an absolute must. The bearings must have high load carrying capacity, be impact resistant and as low maintenance as possible.

Regardless whether it is winding drums, pulleys, rope sheaves, rotation systems or transmissions – Schaeffler provides

optimal technical and economic solutions for any bearing position in draglines and rope excavators. All products used have been approved by machine operators and have proven to be the optimal solution for many of our customers over the years.

Bearings frequently used include:

- Spherical roller bearings
- Large matched tapered roller bearings
- Cylindrical roller bearings

A special solution: Case hardened sheave bearings

Bearings for sheave bearing applications must be designed for heavy loads. Combined radial, axial and tilting forces must be supported reliably. For this purpose, we offer FAG tapered roller bearings made from case hardened steel.

Case hardening or carbonitriding makes rolling bearings less sensitive to vibrations and impacts that may occur during operation. They become more wear-resistant and are characterized by good overrolling resistance as well as reduced susceptibility to cracking. All in all, the result is a longer bearing life.



Increased wear resistance and fatigue strength through case hardening

S p e c i a l S e r v i c e

Detailed defect analyses should be performed as soon as a machine malfunction occurs. Experts at Schaeffler can provide support on site within a very short time. Depending on the type of defect, they use various analytical methods ranging from offline and online condition monitoring to endoscopy. Our diagnostic experts have had many years of experience in many sectors and applications and are familiar with any kind of troubleshooting job, enabling them to detect root causes of defects and work out potential solutions very quickly.



Non-stop operation in surface mining all over the world: Dump trucks



Many impressive Schaeffler solutions are hidden in the huge wheels of dump trucks. They include not only extremely durable wheel bearings for front and rear wheels, but also complete bearing solutions for engines and planetary gears that are integrated into the rear wheels.

The main bearings for the rear wheel, for instance, are designed with two tapered roller bearings up to one meter each in an O arrangement.

The result is a compact design with high load carrying capacity and rigidity that offers a very long service life. One of the reasons: Case hardening makes the bearings less sensitive to vibrations and shock loads. They are more wear-resistant, have good overrolling resis-

tance and reduce crack formation due to surface damage. This increases the rating life of the bearing.

For electric motors we use current-insulated deep-groove ball bearings and cylindrical roller bearings to prevent damage from electric current. These bearings have long relubrication intervals and are suitable for great temperature fluctuations. The ideal solution here is FAG cylindrical roller bearings with robust brass cages.

The planetary gears in the dump trucks primarily contain spherical roller bearings and cylindrical roller bearings. These bearings have very high load carrying capacity – all in a very small mounting space. They also feature narrow tolerances which, in combination with the specially selected internal clearance, permit the loads to be distributed evenly. Thanks to cages customized for this specific application, large centrifugal forces can be absorbed reliably.

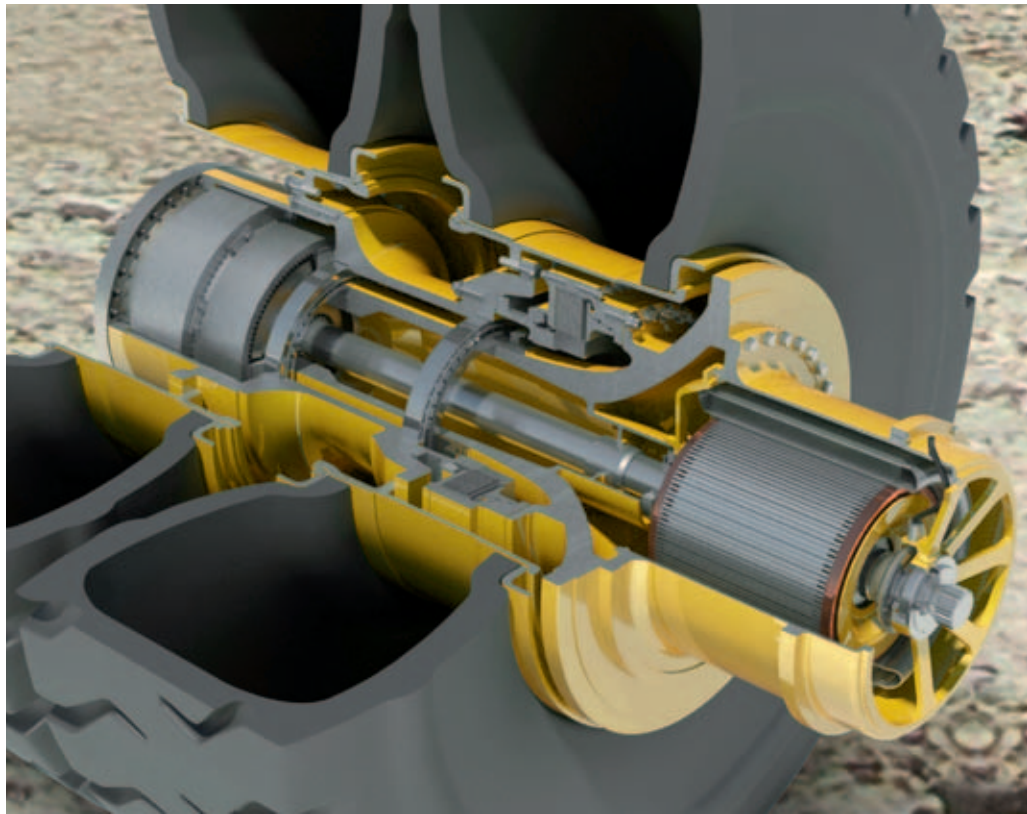

Special Service

Our Schaeffler BEARINX® calculation program allows us to analyze and design every detail of a rolling bearing in order to ensure perfect suitability, even including individual rolling contacts. Factors such as bearing internal clearance, fit and shaft deflection as well as temperature and lubrication are all taken into consideration. Complete load cycles from various loading conditions can be simulated. BEARINX® makes it possible to analyze and optimize several variants in a very early phase of the project.



Indispensable in mining: Conveyor systems



Conveyor systems such as belt conveyors move immense amounts of material across large distances every day, making them indispensable in mining. The main applications for rolling bearings in conveyor systems include gearboxes, pulleys and idlers.

Various types of bearings can be found in conveyor system gearboxes, depending

on the output required, the available mounting space and transmission ratio.

For the drive pulleys, we recommend FAG spherical roller bearings, unsplit or split. Both types are equally capable of withstanding high loads and permit the compensation of misalignments and shaft deflections. From an economic point of view, using split spherical roller bearings is a good solution because replacing these bearings involves significantly fewer steps and less time.

For the non-driven return pulleys, most of which have internal bearings, special cylindrical roller bearings or spherical roller bearings are used. These bearings are particularly durable and very maintenance-friendly due to their long relubrication intervals.

The primary option for idlers is ball bearings because they are very low friction even at high speeds. We supply extremely durable and completely maintenance-free bearings that are lubricated for life.



Split spherical roller bearing



Sealed spherical roller bearing

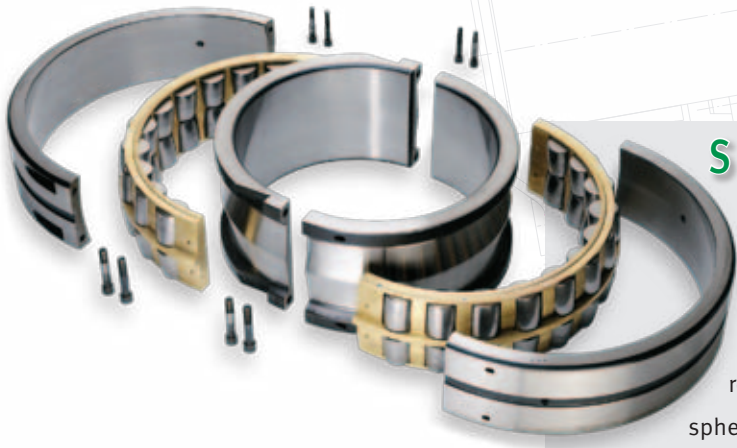

Special Service

It is primarily the reduced downtimes that help reduce costs if split spherical roller bearings are installed. In one specific case, a world

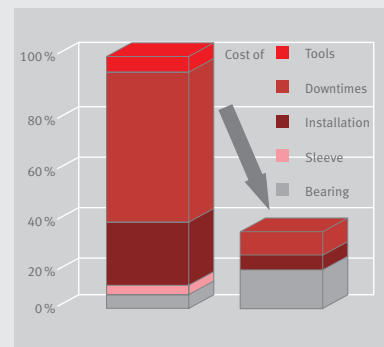

renowned mining company used a split FAG spherical roller bearing in a conveyor system for the first time. Compared to bearing replacements with previously used standard bearings, downtimes were reduced from 22 hours to 3 hours. Overall costs for bearing replacement were reduced by 151,000 euros.

In addition, our product range includes a large selection of housings (unsplit and split) for conveyor systems.

An Innovation – SNS Housings

Schaeffler is setting new standards with its innovative SNS large bearing housing. The unique housing design extends bearing life by as much as 50 percent. This housing provides the best possible sealing effect against dirt ingress even in extreme ambient conditions. SNS housings help you significantly reduce the overall cost of your facilities as defined by total cost of ownership (TCO).

Benefits of the new housing generation:

- Little maintenance required
- Easy to install, e.g. with stopping faces
- Prepared surfaces for monitoring and maintenance devices
- Best sealing effect



SNV housing with split spherical roller bearing

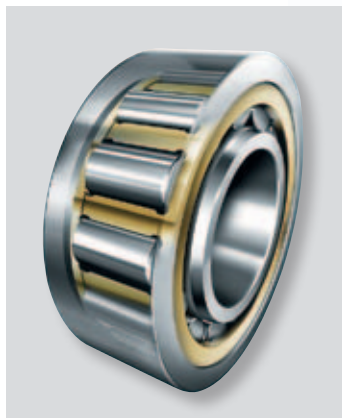

Cylindrical roller bearing with brass cage

SNS housing

Working hard: Crushers

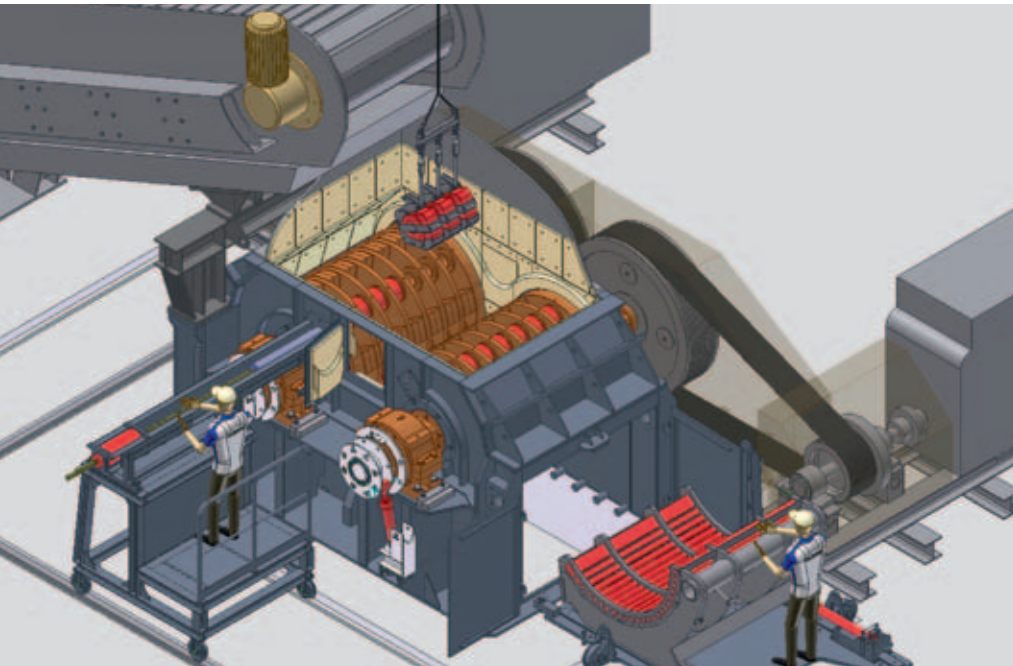

Hammer crusher

The solution:

E1 X-life spherical roller bearings

We recommend FAG E1 spherical roller bearings in X-life quality as the main bearings in jaw crushers. These bearings were developed especially for extremely heavy loads and are used wherever angles must be adjustable. They work reliably even under the toughest ambient conditions.

What are the advantages of X-life quality compared to standard bearings?

- Up to 70% longer service life for the same load – or the same service life for much higher loads
- High static reliability
- Little strain on lubricant due to reduced friction and low bearing temperatures.

For our customers, this means high machine efficiency and reduced operating costs. In addition, downsizing results in more cost-efficient bearing supports.

The challenge

Machines used for crushing require heavy load bearings. In addition, angle adjustability is required to compensate misaligned bearing seats and tilting due to shaft deflection.

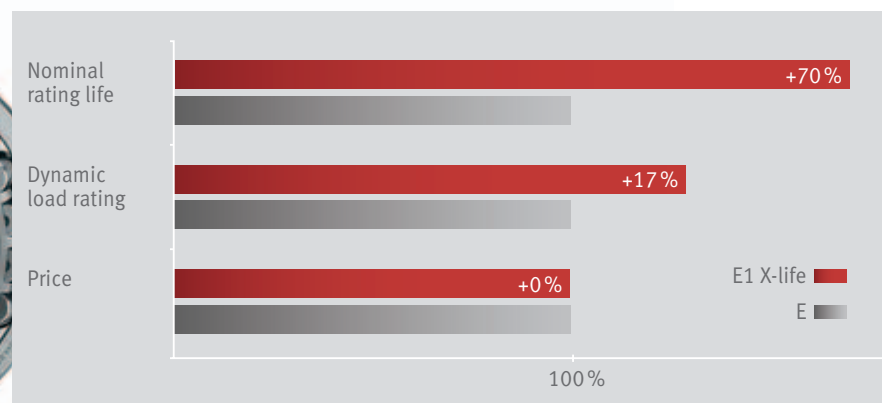

The major benefit of E1 X-life is an increased nominal rating life

High dynamic loads: Vertical mills

Schaeffler has been working closely with all renowned manufacturers of vertical mills for many years. As a result, we have a great deal of experience in designing bearing supports for grinding rolls, rocker arm and rotary air separator.

The challenge

In vertical mills, it is primarily large and dynamic loads that impact the bearings. The following requirements are typical:

- Radial and axial load capacity
- Length compensation of the shaft under load
- High load carrying capacity in a small mounting space
- Nominal rating life of more than 80,000 hours required by the manufacturer

One solution:

Tapered roller bearing units

Thanks to our sophisticated range of products, we are able to provide efficient solutions for all bearing applications. One of the most frequent designs for

grinding rolls is a cylindrical roller bearing used as a floating bearing, in combination with a spherical roller bearing or a tapered roller bearing unit. This allows the contact pressure forces, tilting and axial forces impacting the grinding roll to be supported in the best possible way – the bearings have a high dynamic load capacity.

For this application, the percentage of tapered roller bearing units in an X or O arrangement tends to be higher.

Large FAG tapered roller bearings are characterized by equally high radial and axial load capacity as well as by a large usable speed range. They reliably support forces and ensure precise and rigid shaft guidance. The bearings are adjustable, can be taken apart and are easy to install.

Our product range also includes a large number of special solutions that our application engineers have developed with our customers and implemented in real-life applications.

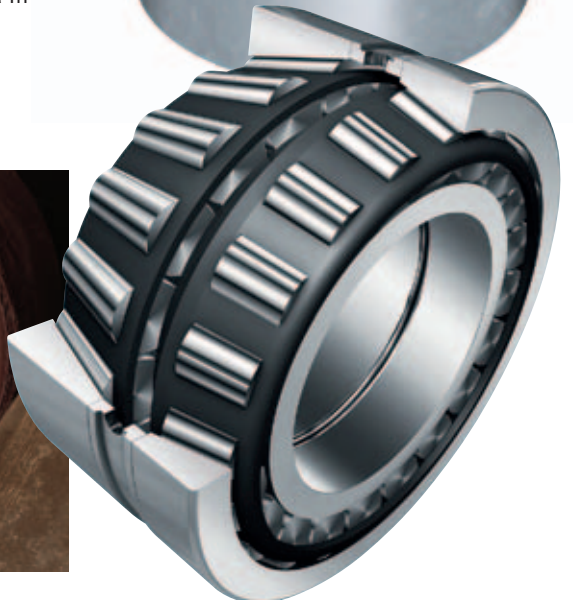

Quadrupole roller mill (cement processing)

High efficiency – low energy: Roller presses



Compared to ball mills, roller presses have greater efficiency and material throughput. Thanks to their 40% lower energy consumption, they are increasingly used in coarse, hybrid and fine grinding.

The challenge

Due to their high load capacity, spherical roller bearings used to be the preferred choice for the rolls in roller presses. However, a development partnership between Schaeffler and leading machine manufacturers has resulted in an extra-

ordinarily efficient and reliable alternative bearing solution.

These were the requirements:

- High radial load capacity
- Optimal use of bearing cross section with limited section height
- Adjustable angle, pressure distribution
- Easy to install, remove, diagnose

An especially economical solution: Four-row cylindrical roller bearings

Four-row FAG cylindrical roller bearings with rollers with through holes and pin cages permit the largest number of rolling bearings possible per row. This results in a very high radial load capacity – up to double that of a spherical roller bearing with the same section height. Four-row cylindrical roller bearings permit much more compact designs. Narrow tolerances of the under roller diameter and the raceway diameter achieve an even load distribution across all rows or rollers.

Being able to take the cylindrical roller bearings apart makes them easy to install.



Four-row large cylindrical roller bearings with pin cage



Schaeffler has produced an extraordinary spherical roller bearing for what is currently the world's largest roller press. The outside diameter is nearly two meters, and each roller weighs 50 kilograms.

High operational reliability required: Ball mills

Schaeffler experts on site: “ASB Grinding Mills Competence Center”

Customers all over the world depend on our Schaeffler experts many years of experience in Melbourne. Services range from design advice to the right support for challenging bearing solutions.

- Development and supply of field-tested bearing and housing units
- Calculation and technical support
- Assistance with repairs and service projects
- Lubricant recommendations for challenging applications

A creative solution:

Sliding sleeve housings

Ball mills are subjected to extreme fluctuations in temperature. Due to the special ambient conditions, innovative bearing designs are required. Our ASB Schaeffler experts provide a full product range here,



comprising spherical roller bearings and sliding sleeve housings. This provides an excellent way of compensating elongations on the horizontal mills. Thus, the floating bearing is no longer displaced between the housing and the sliding plate but between the sliding sleeve and the housing bore. Continuous lubricant

feed between the sliding sleeve and the housing bore ensures a low friction coefficient for ball mill elongations. The benefits for our customer can be measured in economic terms: Elimination of annual bearing replacement – less downtime – increase in production volume.

Special Service

Do you want to detect and localize damage in the gearbox as early as possible? No problem. Schaeffler's FAG Wear Debris Check offers an elegant way to combine oil and vibration monitoring. This oil sensor can be integrated into existing FAG online condition monitoring systems. Combining oil and vibration monitoring enables an even better protection of especially large industrial gearboxes such as those in ball mills or roller presses.

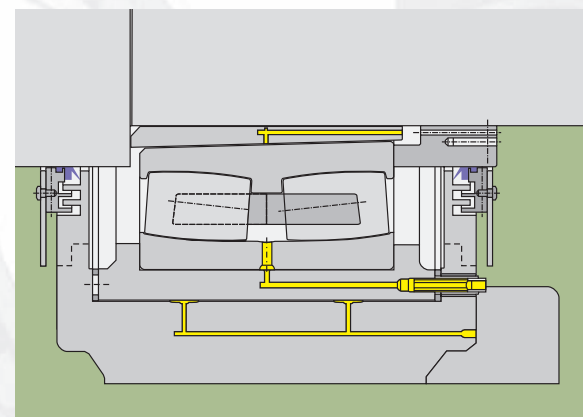

Sliding sleeve housing

Only the very best will do: Vibrating screens



Hardly any industrial bearings have to support loads as high as those impacting vibrating screens. The bearing cages in particular have to withstand high loads due to radial acceleration. Under unfavorable conditions, axial accelerations can be superimposed.

The rotating out of balance generates a circumferential shaft deflection and additional sliding motions in the bearings. This increases friction and thus the operating temperature of the bearings. Despite these tough requirements, a long rating life is still required.

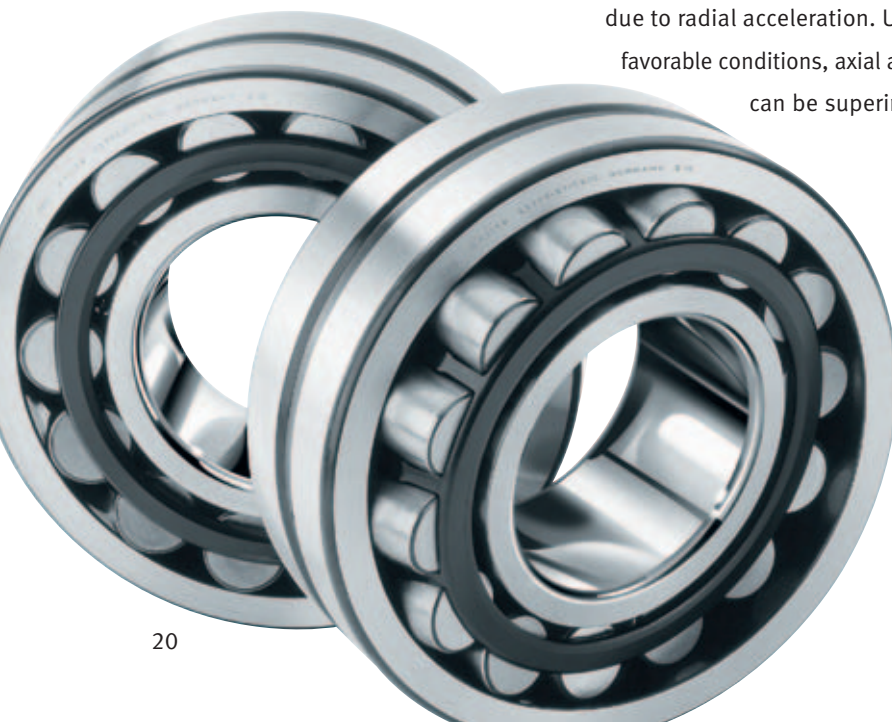

Steel cages for extreme operating temperatures

The solution:

FAG spherical roller bearings with thin-layer chromium-plated bore

Only high-quality, high-performance rolling bearings can withstand the extremely high loads in exciter housings in vibratory machines. Our recommendation: Spherical roller bearings in X-life premium quality. This reliably ensures an up to 70% longer service life than for a “normal” bearing in the same mounting situation.

We supply these bearings with a Durotect® CK coated bore, which provides protection against fretting corrosion. This maintains the possibility of displacement between the bearing bore and the shaft through a long operating time.

The dimensions and tolerances of FAG spherical roller bearings with Durotect® CK coating in the bore meet DIN and ISO standards and are fully interchangeable.

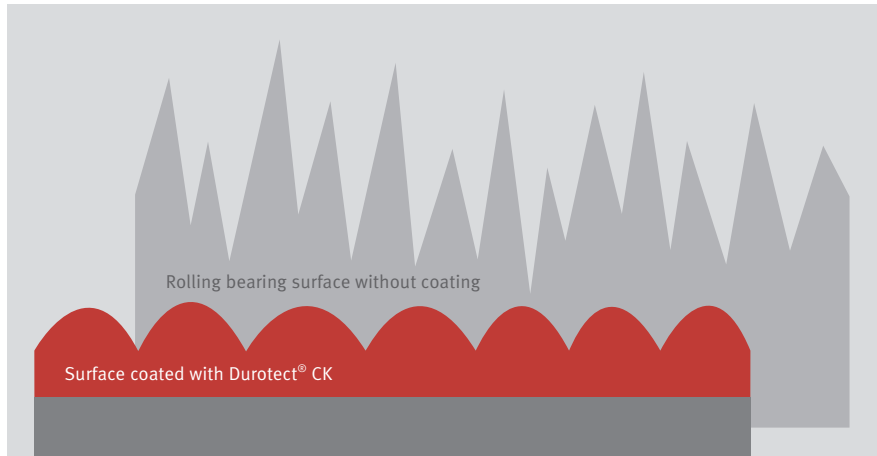

Structure matters: Surfaces coated with Durotect® CK are more resistant to wear and have a friction reducing effect

What are the customer’s benefits?

- Higher operational reliability
- Longer service life due to coated bore
- Support of heavy shock loads and radial acceleration
- No fretting corrosion
- Unhindered thermal expansion of the shaft due to coated inner ring bore
- Very high load capacity

What exactly is Durotect® CK?

Coating with Durotect® CK is part of the family of hard chromium processes. Thanks to a special surface structure, this hard chromium variant has special properties that help reduce friction and wear.

- Layer thickness 1.5 – 3 µm
- Hardness 950 – 1300 HV
- Corrosion protection to DIN 50021 SS 120 hours
- Chemical resistance

Special Service

FAG SmartCheck is used for the remote monitoring of machine vibrations and other process parameters. Typical units include pumps, electric motors, gearboxes and blowers. Our device works smoothly even in special applications such as vibrating screens. When used in a vibrating screen, it reliably detects outer ring damage on a rolling bearing. The damage is detected both when the vibrating screen is idle and when material is used, in spite of the machine’s high vibration level. The early detection of bearing damage permits optimized maintenance planning and can help prevent machine shutdowns. General communication can take place via existing customer networks.



No unplanned shutdowns permitted: Rotary kilns



Rotary kilns represent large investments that tend to be in the range of several million euros. At full capacity, rotary kilns are in operation 24/7. Sudden shutdowns can cause extremely high costs and damage, especially if a cement plant is working with a production line and a rotary kiln.

The challenge

Rotary kiln bearings consist of at least two stations with two radial track rollers. The rollers are subjected to increased temperatures, shock loads, high radial and axial forces and severe dust formation. In addition, the station has two axial track rollers.

The solution: Reliable radial and axial track rollers as complete units

For these bearing positions, Schaeffler provides special assemblies that are often designed to customer specifications.

Radial track rollers consist of a track roller with a shaft, spherical roller bearings with high load capacity and a shared frame housing. On the axial track rollers, the tapered roller bearings are positioned in the hub on a stationary vertical axis that has been shrunk into the base plate. Proven and tested Arcanol greases are used for rolling bearing lubrication because they are more durable than standard lubricants and permit a longer rating life.



Economic solutions from a single source: Axial and radial track rollers as complete assemblies

Tailor-made: Bearing solutions for pellet plants

Pellet plants offer a wide range of potential applications for Schaeffler's quality bearings.

We use special slewing rings as bearing supports for the pellet plates and recommend radial and axial track rollers similar to those in rotary kilns (see p. 22) for pelletizing drums. We have developed special support and track rollers as bearing supports for the pellet and sinter cars used in the subsequent heat treatment process. In smaller machines, the support rollers have a deep groove ball bearing as a locating bearing and a cylindrical roller bearing as a floating bearing on the car axle. In large pellet cars we recommend using bearing packages in O arrangement consisting of two tapered roller bearings. And our complete

units with cylindrical roller bearing supports also represent an efficient solution for the pressure rollers used to turn the cars around.

In the lowering wheels and lifting wheels that are necessary to drive and turn the cars around, large standard spherical roller bearings with special housings provide the best solution. Due to the high forces applied and the extremely high temperatures, selecting the right lubricant can be a challenge. For such cases, we offer suitable greases from our proven and tested Arcanol range. We can provide you with good mounting tools or with our mounting service, especially for the large spherical roller bearings in the lowering and lifting wheels as well as the wheel's interference fit assembly.



Special Service

Inadequate lubrication can affect the rating life of rolling bearings and cause damage. That is why the FAG Arcanol greases are thoroughly checked. Only lubricants meeting the stringent guidelines and tests in the Schaeffler lubricant lab are passed on to our customers. Our consistent and strict inspection procedures are among the most sophisticated on the market. Arcanol greases meet the highest quality requirements.

Depending on the requirements, different Arcanol greases are used. In vibrating screens, for instance, we use Arcanol VIB3 as well as MULTITOP, LOAD400 and LOAD200. If higher operating temperatures are present, thermostable special greases such as Arcanol TEMP120 are a good choice.

arcanol



They're everywhere: Small electric motors and pumps

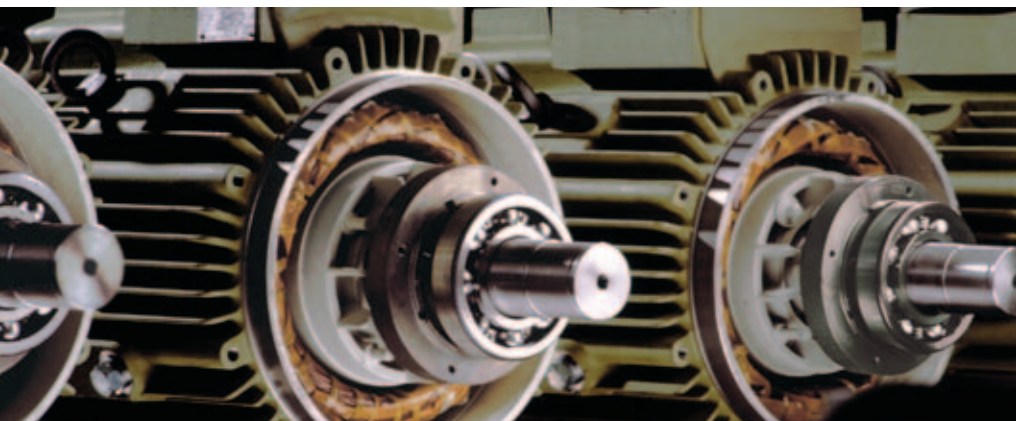

Generation C deep groove ball bearings in electric motors – a good way to save energy costs

Small electric motors used to drive industrial pumps and fans are very common in mining. Small to medium-size deep groove ball bearings or angular contact ball bearings are commonly used here because they are durable and reliable. We recommend FAG Generation C deep groove ball bearings, which are especially quiet and low friction. An optimized

internal design and high manufacturing quality have led to a reduction in internal friction by 35%. This means that the motor uses less energy and the rating life increases because the temperature increases in the ball bearing are not as severe.

X-life bearings in pumps – increasing the overall efficiency of the bearing supports

Bearing supports in pumps are expected to provide reliable support for radial and

axial loads and to be resistant to vibrations and shocks. In addition, durability, a long grease service life and low maintenance are required. Double-row FAG angular contact ball bearings in X-life quality are particularly suitable here. Due to their large pressure angle of 30° they can support high axial loads in both directions.

Our star for both bearings:

The innovative HRS lip seal

Both the deep groove ball bearings and the angular contact ball bearings benefit from the newly developed HRS seal, especially at high speeds. In this range, friction torques and heat generation are much lower than is the case with conventional seals, and they also provide a much higher sealing effect.

Try it!



Double-row angular contact ball bearing and deep groove ball bearing

Sealing action	Z	BRS	HRS
Retaining grease in the bearing	+	++	++
Dust, dry contamination	+	++	++
Damp atmospheres	+	+	++
Liquid spray	-	-	++
Rotating bearing outer ring	+	++	++
Low pressure differences	-	-	++

[++] particularly suitable [+] suitable [-] unsuitable

Fast help: Our certified distributors

Picture this: A transmission bearing essential to the operation of a large bucket wheel excavator fails. Or: The seal and the bearing raceway on the drive drum of a conveyor belt have become downright frayed after a long run time. Both can result in a machine shutdown and high costs. Quick action is required.

Our distributor program ensures that our products and services are made available in the same high quality around the world. In the event of damage, we can help you out fast by providing you with a replacement product either through a local Schaeffler sales office or one of our many distributors. This includes expert mounting services, which are especially important for the large bearings used in mining and processing.

As part of the distributor program, our distributors are certified according to specific criteria and based on a list of services. Among other aspects, this ensures the technical support quality for distributing the premium products of our INA and FAG brands. Training seminars ensure that the distributors know our bearings “inside out” and are able to provide expert advice. In many cases, our distributors have been trained specifically on bearing supports in mining and processing applications.

It is always a good idea for customers to turn to authorized and certified distributors with their concerns. Our authorized distributors have direct access to Schaeffler’s high-performance rolling bearings as original products.

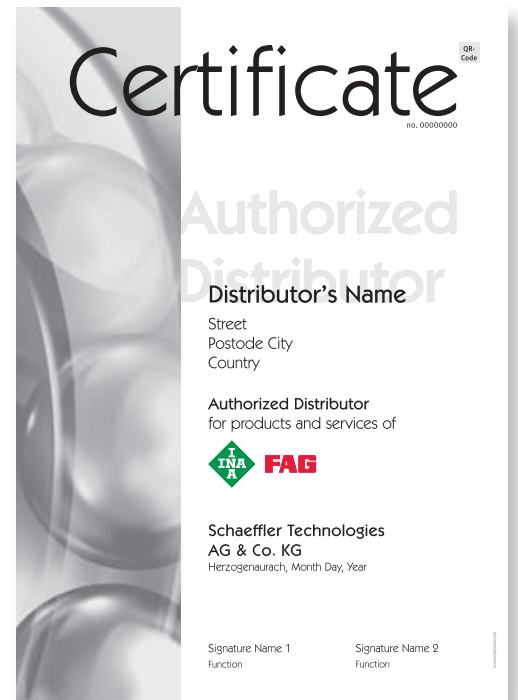

Special Service

Small, powerful and suitable for nearly all grease-lubricated bearings – our FAG GreaseCheck is always one step ahead of rolling bearing damage through the analysis of the lubricating grease. Online monitoring by means of a grease sensor during operation allows rolling bearing damage to be prevented and lubrication to be changed over from a time-based to a demand-based procedure.

The principle is simple: The sensor head is embedded into the lubricant and checks four parameters: water content, clouding, wear and temperature. The intelligent electronic evaluation system generates an analog signal from these parameters that informs the operator about the grease condition. Permanent monitoring and online data output let you see whether the grease condition is good or bad. This saves costs, increases machine availability and, last but not least, is environmentally friendly.



Global expertise – local knowledge – optimum customer performance



Schaeffler has been a renowned development partner for the mining and processing industry for many years. This is not least due to our excellent product quality and

strong individual support. Yet, our thinking is consistently global. You can find our engineering expertise practically anywhere in the world and at a location near you.

Schaeffler Global Technology Network – A strong network for your success

With the Global Technology Network, Schaeffler combines local expertise in each region with the know-how and innovative strength of our experts around the world in one single source. Our local centers of expertise – “Schaeffler Technology Centers“ – let us offer our engineering and service expertise close to you. This combination provides you with optimum support anywhere in the world and our consolidated know-how brings you innovative, customized solutions of the highest quality.

Benefit from our engineers’ experience and expertise!

Locally, anywhere in the world.

Find out more about GTN:

www.global-technology-network.com



Schaeffler Global Technology Network



www.schaeffler.com

More information



Industrial Aftermarket

Products and service for your success

www.schaeffler.com/services



Mining and Processing

The right rolling bearing solution for any application

www.schaeffler.com/Mining_processing

Schaeffler Technologies AG & Co. KG

Georg-Schäfer-Strasse 30

97421 Schweinfurt

Germany

Internet www.fag.com

E-Mail FAGinfo@schaeffler.com

In Germany:

Phone 0180 5003872

Fax 0180 5003873

From other countries:

Phone +49 9721 91-0

Fax +49 9721 91-3435

Every care has been taken to ensure the correctness of the information contained in this publication but no liability can be accepted for any errors or omissions. We reserve the right to make technical changes.

© Schaeffler Technologies AG & Co. KG

Issued: 2013, February

This publication or parts thereof may not be reproduced without our permission.